

o Guide to 65/Not as Common Guide to 65  
□ Guide to 85



Name \_\_\_\_\_  
Mr. Schlansky

Date \_\_\_\_\_  
Geometry

## CCG Regents Review Homework 2026



1. In  $\triangle DEF$ ,  $\angle F$  is the vertex angle. If  $\overline{DF} = 5x + 4$ ,  $\overline{DE} = 12x - 4$ , and  $\overline{EF} = 7x$ , find  $\overline{DE}$ .



2. In  $\triangle ROY$ ,  $m\angle R = 50^\circ$  and  $m\angle O = 95^\circ$ . What is the largest side of  $\triangle ROY$ ? What is the smallest side of  $\triangle ROY$ ?



3. In the diagram of  $\triangle ABC$  below,  $\overline{AB}$  is extended to point  $D$ .

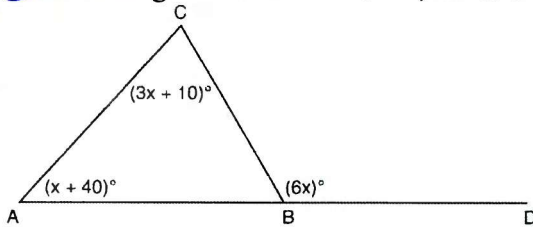

If  $m\angle CAB = x + 40$ ,  $m\angle ACB = 3x + 10$ ,  $m\angle CBD = 6x$ , what is  $m\angle CAB$ ?

- 1) 13
- 2) 25
- 3) 53
- 4) 65



4. Which set of numbers represents the lengths of the sides of a triangle?

- 1)  $\{5, 18, 13\}$
- 2)  $\{6, 17, 22\}$
- 3)  $\{16, 24, 7\}$
- 4)  $\{26, 8, 15\}$



5. In  $\triangle ABC$ ,  $AB = 5$  feet and  $BC = 3$  feet. Which *cannot* represent the value for the length of  $\overline{AC}$ , in feet?

- 1) 3
- 2) 5
- 3) 7
- 4) 9



6. In the diagram below of  $\triangle ABC$ , medians  $\overline{AD}$ ,  $\overline{BE}$ , and  $\overline{CF}$  intersect at  $G$ . If  $CF = 24$ , what is the length of  $\overline{FG}$ ?

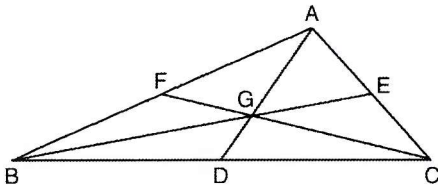

7. Triangle  $ABC$  is graphed on the set of axes below. Graph and label  $\triangle A'B'C'$ , the image of  $\triangle ABC$  after a reflection over the line  $x = 1$ .

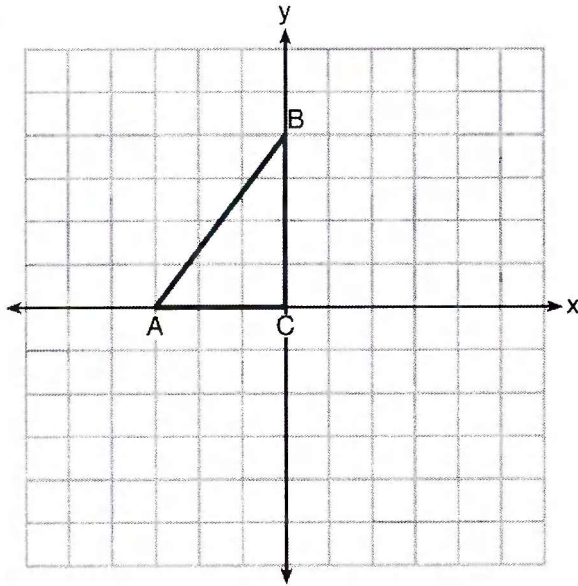



8) On the graph below, point  $A(3,4)$  and  $\overline{BC}$  with coordinates  $B(4,3)$  and  $C(2,1)$  are graphed.

What are the coordinates of  $B'$  and  $C'$  after  $\overline{BC}$  undergoes a dilation centered at point  $A$  with a scale factor of 2?

- 1)  $B'(5,2)$  and  $C'(1,-2)$
- 2)  $B'(6,1)$  and  $C'(0,-1)$
- 3)  $B'(5,0)$  and  $C'(1,-2)$
- 4)  $B'(5,2)$  and  $C'(3,0)$

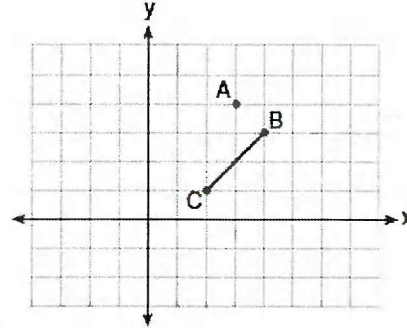

9) Trapezoid  $ABCD$  is graphed on the set of axes below. Trapezoid  $A'B'C'D'$ , whose vertices are  $A'(-7,6)$ ,  $B'(-5,10)$ ,  $C'(-2,10)$ , and  $D'(-2,6)$  is the image of trapezoid  $ABCD$ . What transformation maps trapezoid  $ABCD$  on trapezoid  $A'B'C'D'$ ?

- 1) dilation
- 2) translation
- 3) vertical stretch
- 4) horizontal stretch

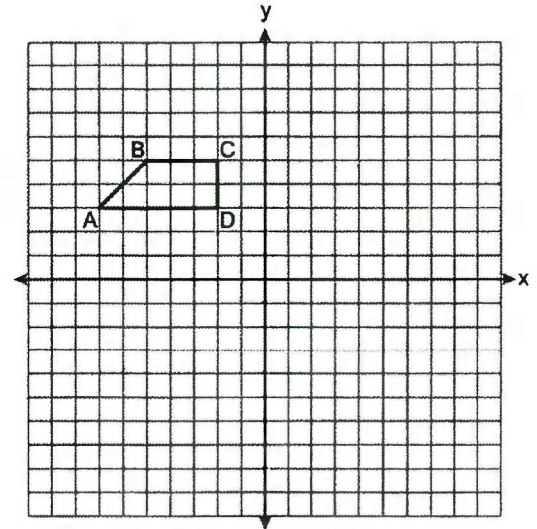

10) The triangle graphed below with vertices at  $A(-2,5)$ ,  $B(4,2)$ , and  $C(-8,-1)$ , is graphed on the set of axes below. A vertical stretch of scale factor 2 with respect to  $y = 0$  is represented by  $(x,y) \rightarrow (x,2y)$ . Graph the image of this triangle, after the vertical stretch on the same set of axes.

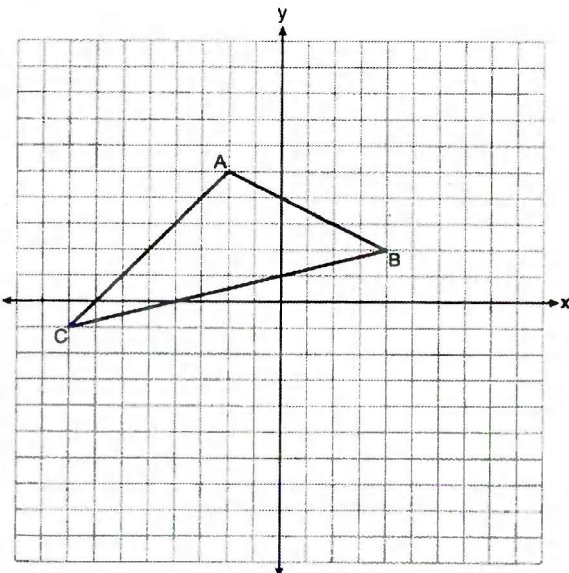



11. On the set of axes below,  $\triangle LET$  and  $\triangle L'E'T'$  are graphed in the coordinate plane where  $\triangle LET \cong \triangle L'E'T'$ .

- Which sequence of rigid motions maps  $\triangle LET$  onto  $\triangle L'E'T'$ ?
- 1) a reflection over the  $y$ -axis followed by a reflection over the  $x$ -axis
  - 2) a rotation of  $180^\circ$  about the origin
  - 3) a rotation of  $90^\circ$  counterclockwise about the origin followed by a reflection over the  $y$ -axis
  - 4) a reflection over the  $x$ -axis followed by a rotation of  $90^\circ$  clockwise about the origin

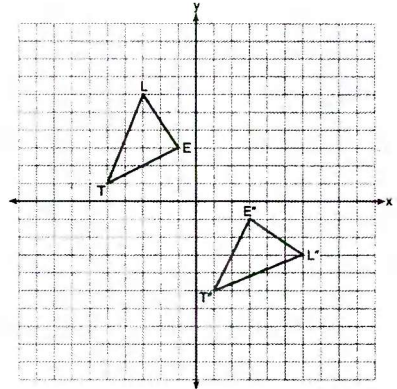

12. The graph below shows  $\triangle ABC$  and its image,  $\triangle A'B'C'$ . Describe a sequence of rigid motions which would map  $\triangle ABC$  onto  $\triangle A'B'C'$ .

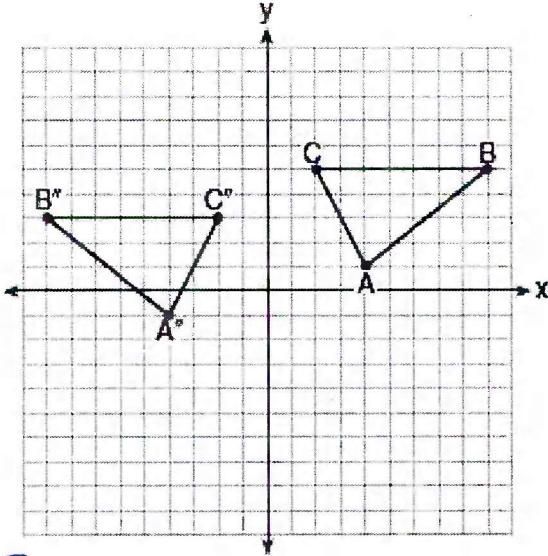

13. On the set of axes below,  $\triangle ABC$  and  $\triangle DEF$  are graphed. Describe a sequence of rigid motions that would map  $\triangle ABC$  onto  $\triangle DEF$ .

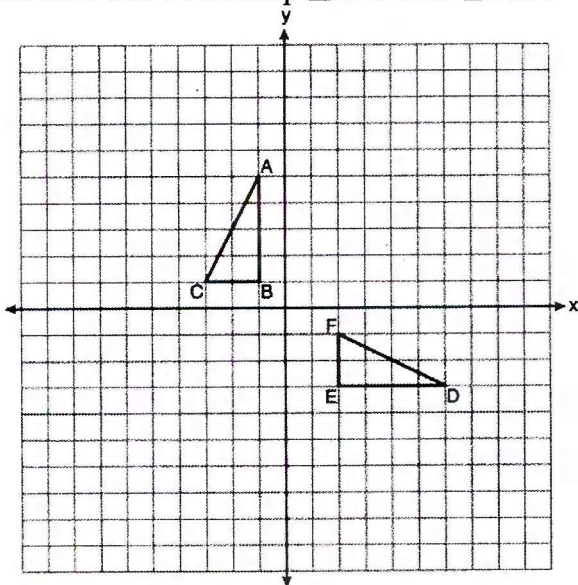



- 14) If  $\triangle A'B'C'$  is the image of  $\triangle ABC$ , under which transformation will the triangles *not* be congruent?
- 1) reflection over the  $x$ -axis
  - 2) translation to the left 5 and down 4
  - 3) dilation centered at the origin with scale factor 2
  - 4) rotation of  $270^\circ$  counterclockwise about the origin



- 15) In the diagram below, parallelogram  $EFGH$  is mapped onto parallelogram  $IJKH$  after a reflection over line  $\ell$ . Use the properties of rigid motions to explain why parallelogram  $EFGH$  is congruent to parallelogram  $IJKH$ .

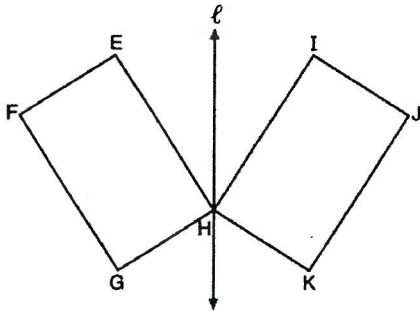

- 16) Which rotation would map a regular hexagon onto itself?
- 1)  $45^\circ$
  - 2)  $150^\circ$
  - 3)  $240^\circ$
  - 4)  $315^\circ$



- 17) As shown in the graph below, the quadrilateral is a rectangle. Which transformation would *not* map the rectangle onto itself?
- 1) a reflection over the  $x$ -axis
  - 2) a reflection over the line  $x = 4$
  - 3) a rotation of  $180^\circ$  about the origin
  - 4) a rotation of  $180^\circ$  about the point  $(4, 0)$

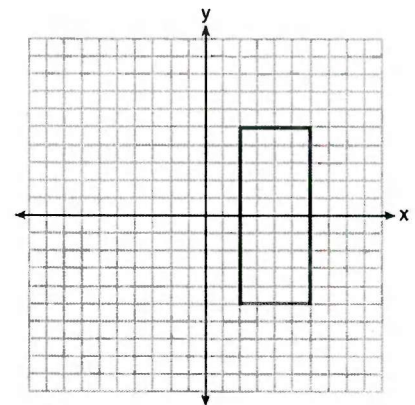

- 18) In the diagram below,  $\overline{AD}$  intersects  $\overline{BE}$  at  $C$ , and  $\overline{AB} \parallel \overline{DE}$ . If  $CD = 6.6$  cm,  $DE = 3.4$  cm,  $CE = 4.2$  cm, and  $BC = 5.25$  cm, what is the length of  $\overline{AC}$ , to the nearest hundredth of a centimeter?

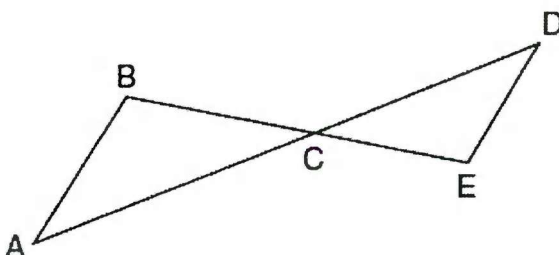



19. In  $\triangle AGL$  below,  $N$  and  $E$  are the midpoints of  $\overline{AG}$  and  $\overline{AL}$ , respectively,  $\overline{NE}$  is drawn. If  $NE = 15$  and  $GL = 3x - 12$ , determine and state the value of  $x$ .

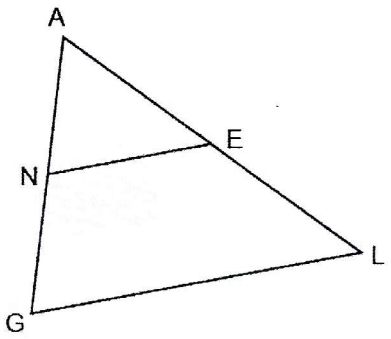

20. Given  $\triangle MRO$  shown below, with trapezoid  $PTRO$ ,  $MR = 9$ ,  $MP = 2$ , and  $PO = 4$ . What is the length of  $TR$ ?

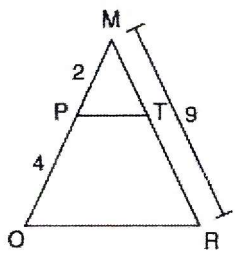

21. To find the distance across a pond from point  $B$  to point  $C$ , a surveyor drew the diagram below. The measurements he made are indicated on his diagram. Use the surveyor's information to determine and state the distance from point  $B$  to point  $C$ , to the nearest yard.

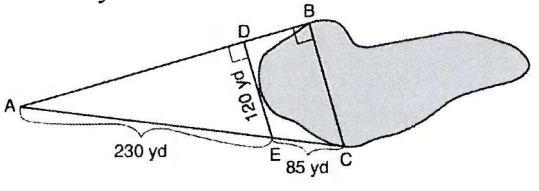



22. In the diagram below of  $\triangle ABC$ ,  $X$  and  $Y$  are points on  $\overline{AB}$  and  $\overline{AC}$ , respectively, such that  $m\angle AYX = m\angle B$ . If  $\overline{AX} = 2$ ,  $\overline{AY} = 5$ , and  $\overline{YC} = 4$ , find  $\overline{BX}$ .

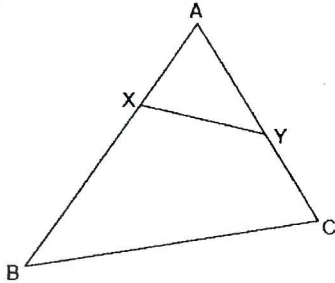

23. Triangle  $ABC$  shown below is a right triangle with altitude  $\overline{AD}$  drawn to the hypotenuse  $\overline{BC}$ . If  $BD = 2$  and  $DC = 10$ , what is the length of  $\overline{AB}$  to the nearest tenth?

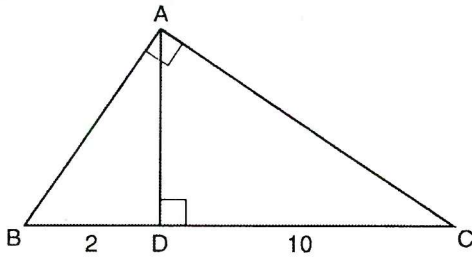

24. In the diagram below of right triangle  $ABC$ , altitude  $\overline{BD}$  is drawn to hypotenuse  $\overline{AC}$ ,  $AC = 16$ , and  $CD = 7$ . What is the length of  $\overline{BD}$  to the nearest tenth?

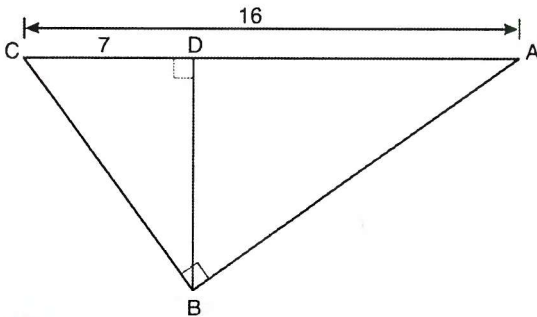

25. In the diagram below, a sequence of rigid motions maps  $ABCD$  onto  $JKLM$ .

Which of the following statements must be true?

- 1)  $\angle L \cong \angle B$
- 2)  $\angle A \cong \angle J$
- 3)  $\overline{JK} \cong \overline{AC}$
- 4)  $\overline{JM} \cong \overline{AB}$

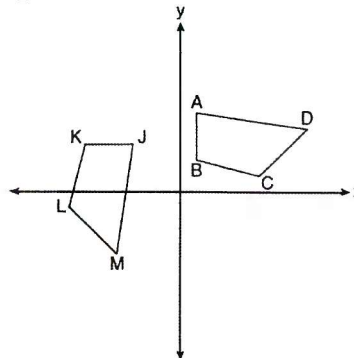



30. In the diagram below,  $\angle GRS \cong \angle ART$ ,  $GR = 36$ ,  $SR = 45$ ,  $AR = 15$ , and  $RT = 18$ .

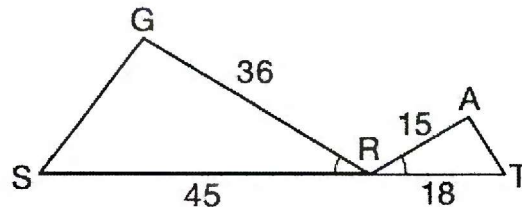

Which triangle similarity statement is correct?

- 1)  $\triangle GRS \sim \triangle ART$  by AA.                      3)  $\triangle GRS \sim \triangle ART$  by SSS.  
 2)  $\triangle GRS \sim \triangle ART$  by SAS.                4)  $\triangle GRS$  is not similar to  $\triangle ART$ .

31. Find the center of dilation AND the scale factor if  $\triangle RST$  is the image of  $\triangle ABC$

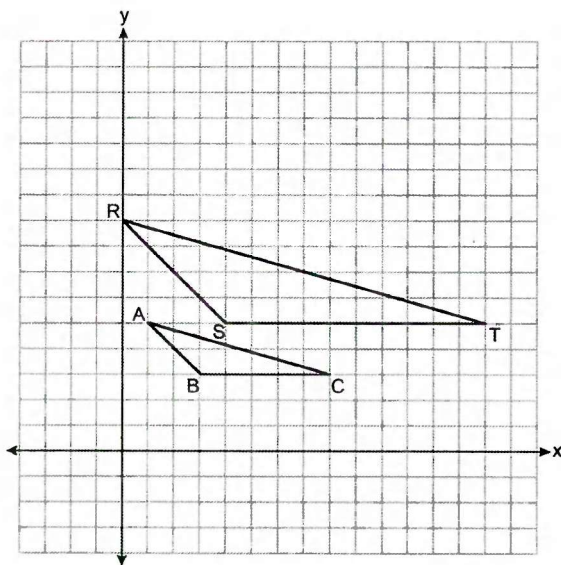

32. Triangle JOY has a perimeter of 10 and an area of 12. What is the perimeter and area of triangle JOY after a dilation by a scale factor of 2?





33) Which equation shows a correct trigonometric ratio for angle  $A$  in the right triangle below?

- 1)  $\sin A = \frac{15}{17}$
- 2)  $\tan A = \frac{8}{17}$
- 3)  $\cos A = \frac{15}{17}$
- 4)  $\tan A = \frac{5}{8}$

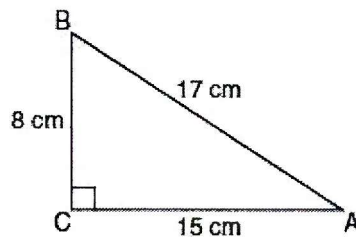

34) A 28-foot ladder is leaning against a house. The bottom of the ladder is 6 feet from the base of the house. Find the measure of the angle formed by the ladder and the ground, to the *nearest degree*.



35) Cape Canaveral, Florida is where NASA launches rockets into space. As modeled in the diagram below, a person views the launch of a rocket from observation area  $A$ , 3280 feet away from launch pad  $B$ . After launch, the rocket was sighted at  $C$  with an angle of elevation of  $15^\circ$ . The rocket was later sighted at  $D$  with an angle of elevation of  $31^\circ$ . Determine and state, to the *nearest foot*, the distance the rocket traveled between the two sightings,  $C$  and  $D$ .

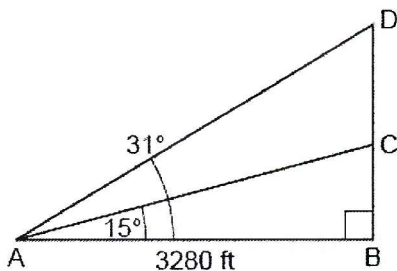





41. In right triangle  $ABC$  below,  $m\angle C = 90^\circ$ ,  $m\angle B = 30^\circ$ , and  $CB = 6\sqrt{3}$ .

The length of  $\overline{AB}$  is

- 1)  $3\sqrt{3}$
- 2) 9
- 3) 12
- 4)  $12\sqrt{3}$

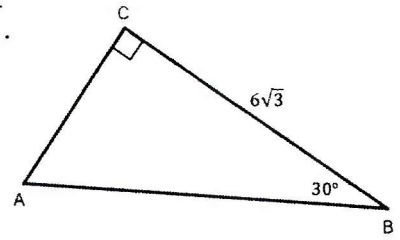

42. A plane intersects a cylinder parallel to its bases.

This cross section can be described as a

- 1) rectangle
- 2) parabola
- 3) triangle
- 4) circle

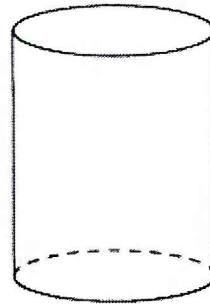

43. A right hexagonal prism is shown below. A two-dimensional cross section that is perpendicular to the base is taken from the prism.

Which figure describes the two-dimensional cross section?

- 1) triangle
- 2) rectangle
- 3) pentagon
- 4) hexagon

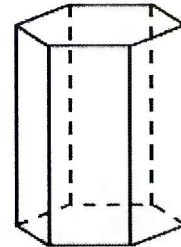

44. Find the area of  $PQR$ .

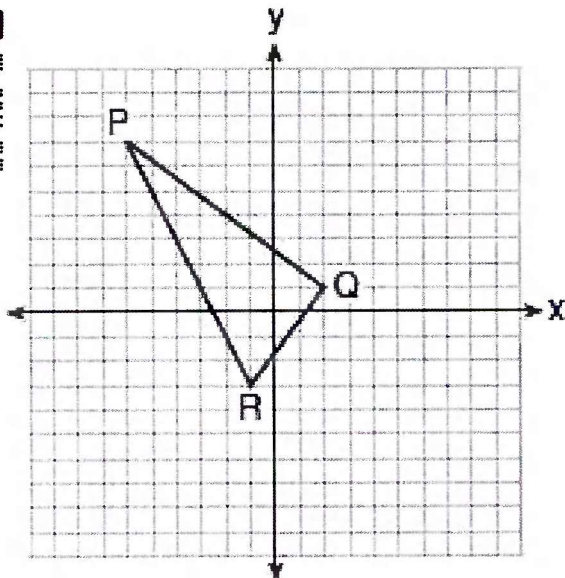

- 45 Find the area of  $ABC$  to the nearest tenth of a unit.

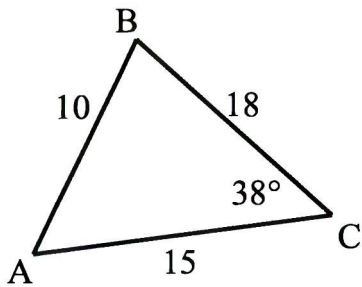

- 46 A regular pyramid has a square base with an edge length of 14 cm and an altitude of 24 cm. Find its volume.

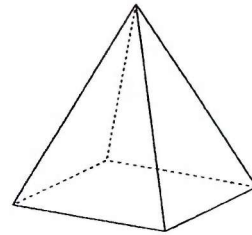

47. Determine and state the volume of the cone, in terms of  $\pi$ .

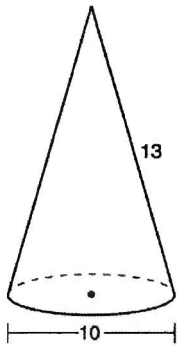

48. In the year 2020, the village of Depew, New York had an area of 5.1 square miles and a population of 15,069. In the same year, the village of Lancaster, New York had an area of 2.7 square miles and a population of 10,087. Which village had the larger population density in 2020? Justify your answer.

49. Clay in the shape of a triangular prism shown below has a mass of 1260 grams. What is its density?

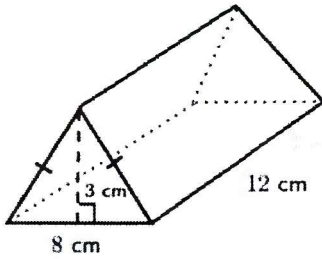

50. Find the volume of the figure below to the *nearest tenth of a foot*.

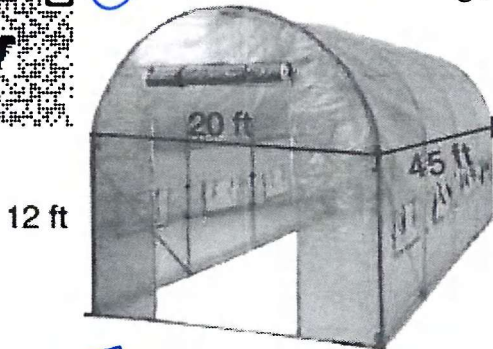

51. A hollow cylinder has a height of 10 inches, an outer diameter of 5 inches, and a thickness of 1 inch. Find the volume to the hollow cylinder to the nearest cubic inch.



52. Find the volume of a cone whose diameter is 15 inches and height of 2 feet rounded to the *nearest cubic foot*.



53. Walter wants to make 100 candles in the shape of a cone for his new candle business. The mold shown below will be used to make the candles. Each mold will have a height of 8 inches and a diameter of 3 inches.

Walter goes to a hobby store to buy the wax for his candles. The wax costs \$0.10 per ounce. If the weight of the wax is 0.52 ounce per cubic inch, how much will it cost Walter to buy the wax for 100 candles?

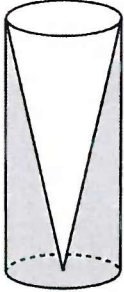

54. Ian needs to replace two concrete sections in his sidewalk, as modeled below. Each section is 36 inches by 36 inches and 4 inches deep. He can mix his own concrete for \$3.25 per cubic foot. How much money will it cost Ian to replace the two concrete sections?

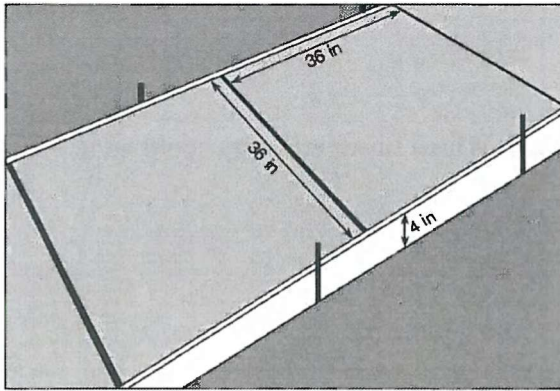

\*55. Baseballs that have a diameter of 2.8 inches are to be packed into a rectangular shipping box that has dimensions 24 inches by 12 inches by 6 inches. What is the maximum number of baseballs that can fit into the shipping box?



56. In the diagram below, right triangle  $ABC$  has legs whose lengths are 4 and 6. What is the volume, in terms of  $\pi$ , of the three-dimensional object formed by continuously rotating the right triangle around  $\overline{AB}$ ?

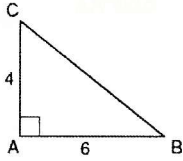

57. The line  $y = 3x - 2$  is dilated by a scale factor of 2 and centered at the origin. Write an equation that represents the image of the line after the dilation.

- 1)  $y = 3x - 2$                       3)  $y = 6x - 2$   
2)  $y = 3x - 4$                       4)  $y = 6x - 4$



58. The line  $y = 3x - 2$  is dilated by a scale factor of 2 and centered at  $(-1, -5)$ . Write an equation that represents the image of the line after the dilation.

- 1)  $y = 3x - 2$   
2)  $y = 3x - 4$   
3)  $y = 6x - 2$   
4)  $y = 6x - 4$



59. The line  $y = \frac{2}{3}x + 3$  is dilated centered at the origin. Which linear equation could be its image?

- 1)  $2x + 3y = 7$                       3)  $3x - 2y = 7$   
2)  $2x - 3y = 7$                       4)  $3x + 2y = 7$



60. What is the equation of a line that passes through the point  $(-3, -11)$  and is parallel to the line whose equation is  $y = 2x - 4$ ?

- 1)  $y = 2x + 5$                       3)  $y = \frac{1}{2}x + \frac{25}{2}$   
2)  $y = 2x - 5$                       4)  $y = -\frac{1}{2}x - \frac{25}{2}$



61. What is an equation of the line that passes through the point  $(6, 8)$  and is perpendicular to a line with equation  $y = \frac{3}{2}x + 5$ ?

- 1)  $y - 8 = \frac{3}{2}(x - 6)$
- 2)  $y - 8 = -\frac{2}{3}(x - 6)$
- 3)  $y + 8 = \frac{3}{2}(x + 6)$
- 4)  $y + 8 = -\frac{2}{3}(x + 6)$



62. Line segment  $NY$  has endpoints  $N(-11, 5)$  and  $Y(5, -7)$ . What is the equation of the perpendicular bisector of  $NY$ ?

- 1)  $y + 1 = \frac{4}{3}(x + 3)$
- 2)  $y + 1 = -\frac{3}{4}(x + 3)$
- 3)  $y - 6 = \frac{4}{3}(x - 8)$
- 4)  $y - 6 = -\frac{3}{4}(x - 8)$

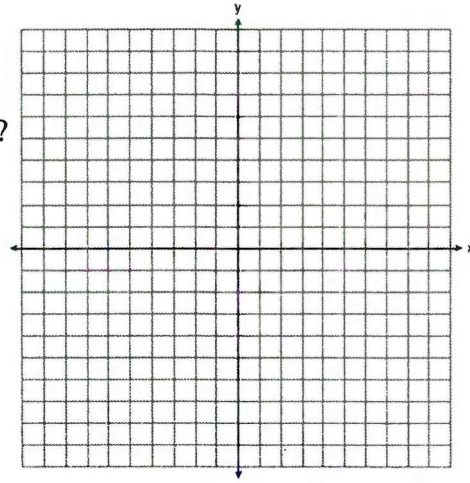

63. Which of the following is the equation of the given circle?

- 1)  $(x - 3)^2 + (y - 2)^2 = 25$
- 2)  $(x + 3)^2 + (y + 2)^2 = 25$
- 3)  $(x - 3)^2 + (y - 2)^2 = 5$
- 4)  $(x + 3)^2 + (y + 2)^2 = 5$

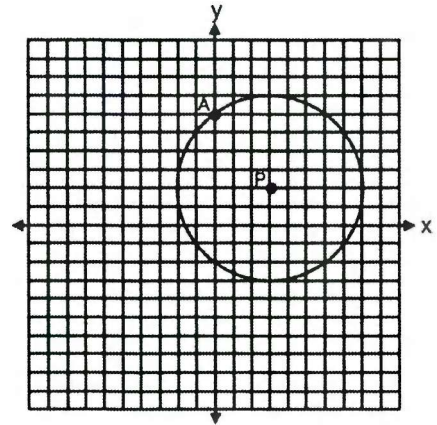

64. State the center and the exact value of the radius of  $x^2 + y^2 - 4x + 8y + \frac{31}{4} = 0$





- 65 Directed line segment  $\overrightarrow{SB}$  has endpoints whose coordinates are  $S(-6,3)$  and  $B(9,-2)$ . Determine the coordinates of point  $J$  that divides the segment in the ratio 2 to 3.

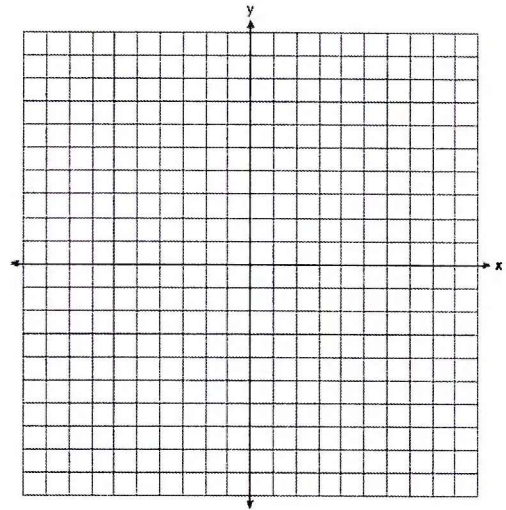

- 66 As shown in the diagram below, secants  $\overrightarrow{PWR}$  and  $\overrightarrow{PTS}$  are drawn to circle  $O$  from external point  $P$ .

If  $m\angle RPS = 35^\circ$  and  $m\widehat{RS} = 121^\circ$ , determine and state  $m\widehat{WT}$ .

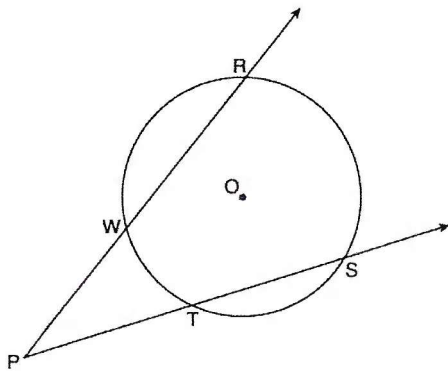

- 67 In the diagram below of circle  $O$ , chords  $\overline{AB}$  and  $\overline{CD}$  intersect at  $E$ . If  $m\angle AEC = 34$  and  $m\widehat{AC} = 50$ , what is  $m\widehat{DB}$ ?

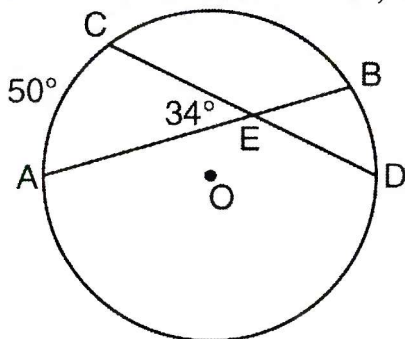

68. In the diagram,  $\overline{AD}$  is tangent to circle  $O$  at  $D$ , and  $\overline{CBA}$  is a secant. If  $AD = 6$  and  $AC = 9$ , what is  $AB$ ?

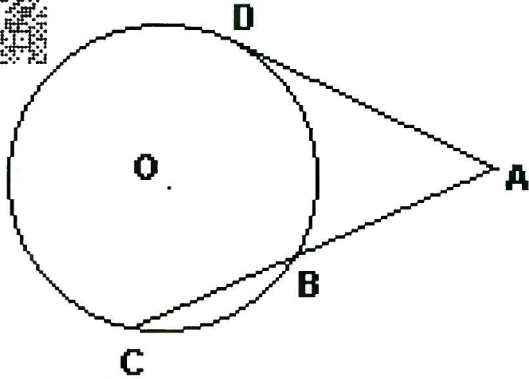

69. In the diagram below of circle  $O$ , chords  $\overline{AB}$  and  $\overline{CD}$  intersect at  $E$ . If  $CE = 10$ ,  $ED = 6$ , and  $AE = 4$ , what is the length of  $EB$ ?

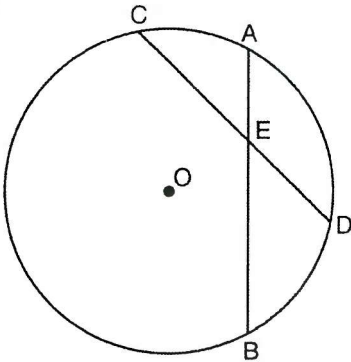

70. In circle  $O$  two secants,  $\overline{ABP}$  and  $\overline{CDP}$ , are drawn to external point  $P$ . If  $m\widehat{AC} = 72^\circ$ , and  $m\widehat{BD} = 34^\circ$ , what is the measure of  $\angle P$ ?



71. In the diagram below, quadrilateral  $SBRE$  is inscribed in the circle. If  $m\angle BRE = 91^\circ$  and  $m\angle SBR = 40^\circ$ , find  $m\angle BSE$  and  $m\angle SER$

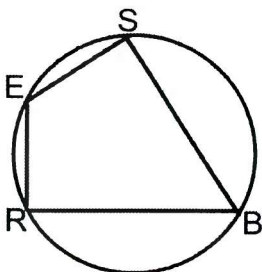



72. In the diagram below of circle  $O$ ,  $GO = 8$  and  $m\angle GOJ = 60^\circ$ . What is the area, in terms of  $\pi$ , of the shaded region?

- 1)  $\frac{4\pi}{3}$
- 2)  $\frac{20\pi}{3}$
- 3)  $\frac{32\pi}{3}$
- 4)  $\frac{160\pi}{3}$

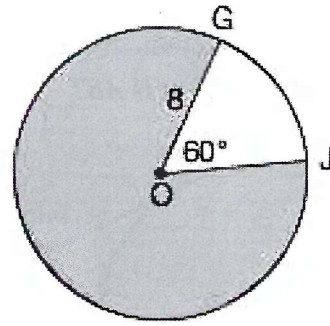

73. The diagram below shows circle  $O$  with radii  $\overline{OA}$  and  $\overline{OB}$ . The measure of angle  $AOB$  is  $120^\circ$ , and the length of a radius is 6 inches. Find the length of arc  $AB$ , to the nearest inch.

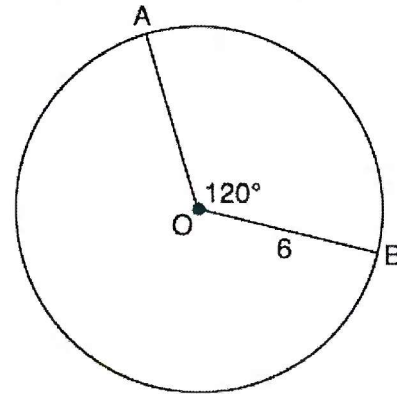

74. The volume of a cylinder is  $12,566.4 \text{ cm}^3$ . The height of the cylinder is 8 cm. Find the radius of the cylinder to the nearest tenth of a centimeter.

- 1) 12.3
- 2) 22.4
- 3) 7.9
- 4) 501.8

\*75. Altitude  $\overline{CD}$  is drawn to right triangle  $ABC$ . If  $\overline{AC} = 8$ ,  $\overline{AB} = x$ , and  $\overline{AD} = x - 12$ . Find the measure of  $\overline{AD}$ .

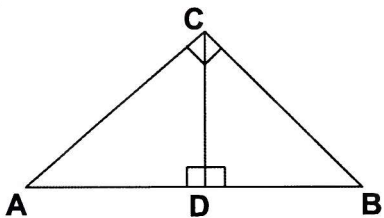

- \*76 In the diagram below of circle  $O$ , chord  $\overline{AB}$  bisects chord  $\overline{CD}$  at  $E$ . If  $AE = 8$  and  $BE = 9$ , find the length of  $\overline{CE}$  in simplest radical form.

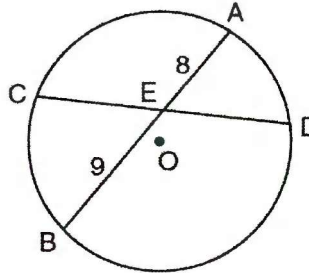

77. A parallelogram must be a rectangle when its
- 1) diagonals are perpendicular
  - 2) diagonals are congruent
  - 3) opposite sides are parallel
  - 4) opposite sides are congruent



78. If  $ABCD$  is a parallelogram, which statement would prove that  $ABCD$  is a rhombus?
- |                                        |                                        |
|----------------------------------------|----------------------------------------|
| 1) $\angle ABC \cong \angle CDA$       | 3) $\overline{AC} \perp \overline{BD}$ |
| 2) $\overline{AC} \cong \overline{BD}$ | 4) $\overline{AB} \perp \overline{CD}$ |



79. A rhombus has diagonals that measure 6 and 8. Find the perimeter of the rhombus.

80. In the diagram below,  $\overleftrightarrow{CT} \parallel \overleftrightarrow{AR}$ , and  $\overline{ACE}$  and  $\overline{RC}$  are drawn such that  $\overline{AC} \cong \overline{RC}$ . If  $m\angle ECT = 75^\circ$ , what is  $m\angle ACR$ ?

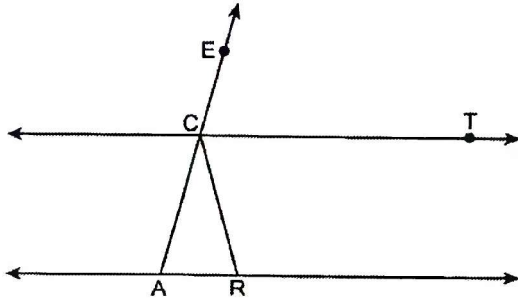

81. In the diagram below,  $ABCD$  is a parallelogram,  $\overline{AB}$  is extended through  $B$  to  $E$ , and  $\overline{CE}$  is drawn.

If  $\overline{CE} \cong \overline{BE}$  and  $m\angle D = 112^\circ$ , what is  $m\angle E$ ?

- 1)  $44^\circ$
- 2)  $56^\circ$
- 3)  $68^\circ$
- 4)  $112^\circ$

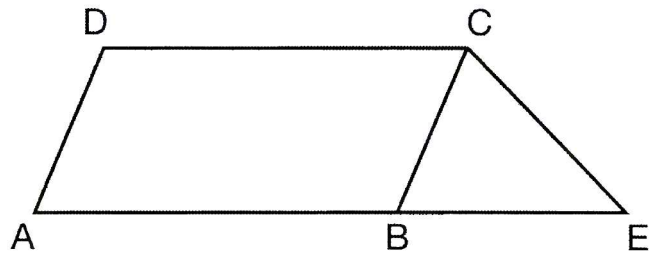

82. Find the perimeter of  $ABCDEF$  in simplest radical form.

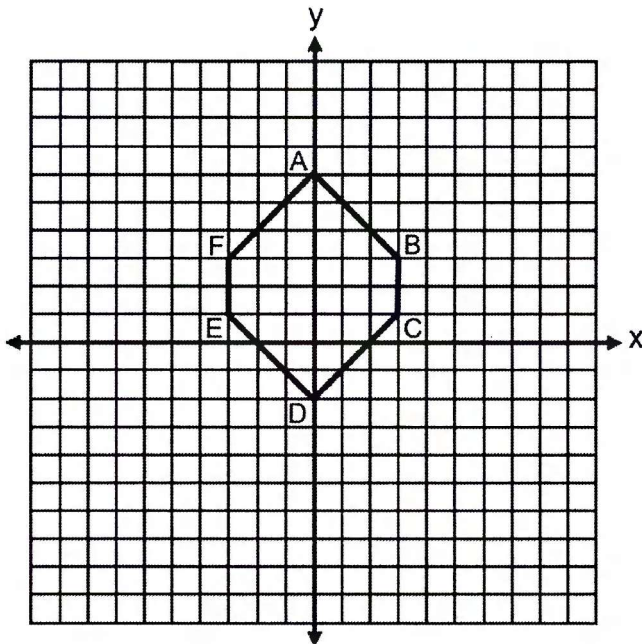



83) A triangle has vertices  $A(-2, 4)$ ,  $B(6, 2)$ , and  $C(1, -1)$ . Prove that  $\triangle ABC$  is an isosceles right triangle. [The use of the set of axes below is optional.]

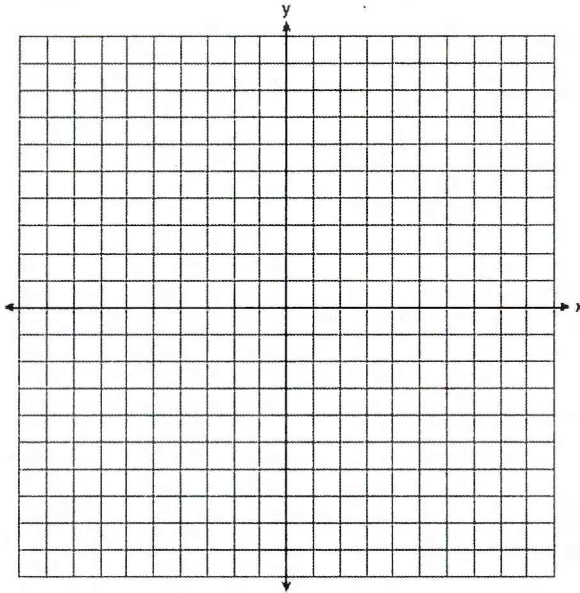

84) Quadrilateral  $PQRS$  has vertices  $P(-2, 3)$ ,  $Q(3, 8)$ ,  $R(4, 1)$ , and  $S(-1, -4)$ . Prove that  $PQRS$  is a rhombus. Prove that  $PQRS$  is *not* a square. [The use of the set of axes below is optional.]

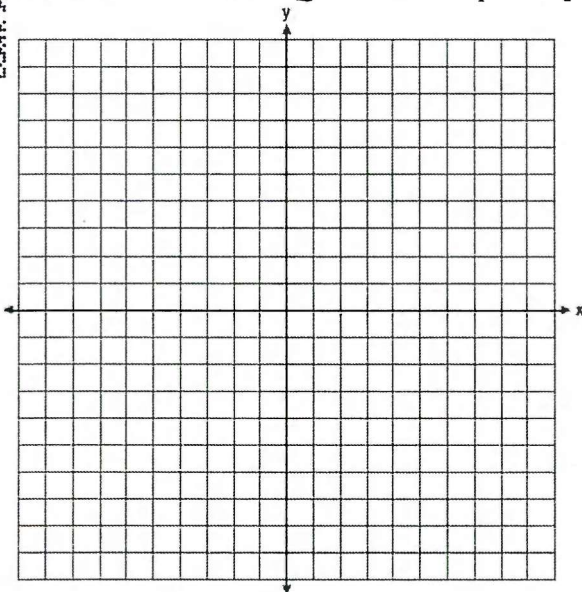



85. Quadrilateral  $DEFG$  has vertices  $D(1,3)$   $E(-1,1)$   $F(-1,-2)$   $G(4,3)$ . Prove that  $DEFG$  is an isosceles trapezoid.

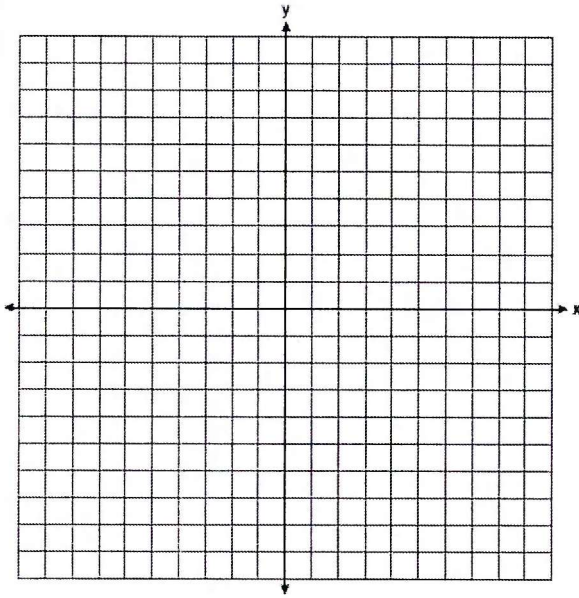

86. Given: Triangle  $DUC$  with coordinates  $D(-3,-1)$ ,  $U(-1,8)$ , and  $C(8,6)$

Prove:  $\triangle DUC$  is a right triangle

Point  $U$  is reflected over  $\overline{DC}$  to locate its image point,  $U'$ , forming quadrilateral  $DUCU'$ .

Prove quadrilateral  $DUCU'$  is a square.

[The use of the set of axes below is optional.]

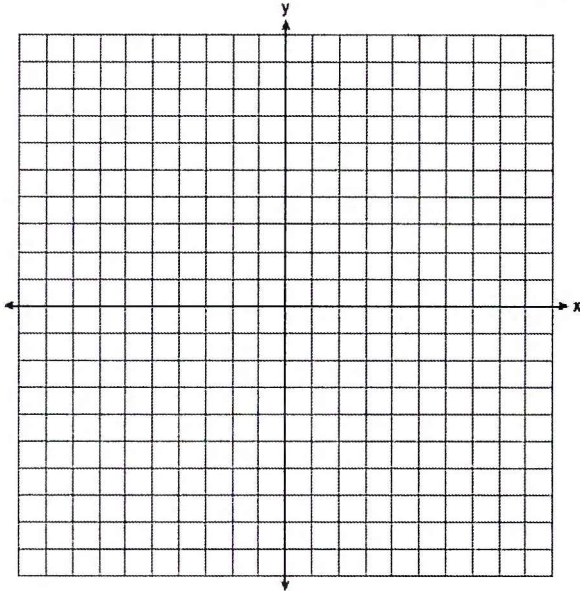

$\sin A = \cos B$   
 $A + B = 90$

Enhanced by Schlansky!  
 2026

Conics Appl  
 Alpha Enter!

Ratio Partitions  
 $\frac{\Delta x}{p} \quad \frac{\Delta y}{p}$

Reference Sheet for Geometry (NGLS)

Scale Factor =  $\frac{\text{image}}{\text{original}}$

Perimeter (scale factor)  
 area (scale factor)<sup>2</sup>

line of reflection = line of symmetry  
 center of rotation = center of shape

min rotation =  $\frac{360}{n}$   
 and any multiple of that

density =  $\frac{\text{mass}}{\text{Volume}}$   
 Population density =  $\frac{\text{Population}}{\text{area}}$

Cylinder	$V = Bh$ where B is the area of the base
General Prism	$V = Bh$ where B is the area of the base
Sphere	$V = \frac{4}{3}\pi r^3$
Cone	$V = \frac{1}{3}Bh$ where B is the area of the base
Pyramid	$V = \frac{1}{3}Bh$ where B is the area of the base

$d = \sqrt{\Delta x^2 + \Delta y^2}$   
 $m = \frac{\Delta y}{\Delta x}$

$y - y_1 = m(x - x_1)$   
 might have to distribute and isolate y

Rectangle: CD RA, congruent diagonals, right angle  
 Rhombus: PD LSC DBA, perpendicular diagonals, consecutive sides congruent, diagonals bisect angles

Rectangular Prism  $V = lwh$

Triangular Prism  $V = \frac{1}{2}lwh$

Pyramid  $V = \frac{1}{3}lwh$

Cylinder  $V = \pi r^2 h$

Cone  $V = \frac{1}{3}\pi r^2 h$

Triangle Area

$A = \frac{1}{2}ab \sin C$

"I can't remember doing this!"  
 ICEDT

$A = \frac{\theta \pi r^2}{360}$

$L = \frac{\theta \pi r}{360}$

$2(\angle A) = \text{major} - \text{minor}$   
 $2(\angle A) = \text{arc} + \text{arc}$  } arcs and angles

Area of a sector

Arc Length

P.P = P.P } segments  
 w.e = w.e

Look for:  
 Inscribed  
 Central  
 Radii  
 Diameters  
 Tangents

Look for linear pair and angles of a triangle

# P-gram Properties

# Coordinate Geometry Proofs

$$d = \sqrt{\Delta x^2 + \Delta y^2}$$

$$m = \frac{\Delta y}{\Delta x}$$

MP =  $(\frac{y_1 + y_2}{2}, \frac{x_1 + x_2}{2})$   
or  
exhibit it

Isosceles Triangle  $\triangle$   
 Equilateral Triangle  $\triangle$   
 Right Triangle:  $a^2 + b^2 = c^2$

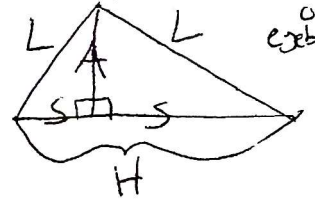

Parallelogram  $\square$

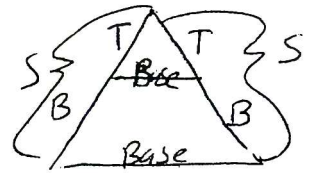

Rhombus  $\square$

Candy Corn  
 Base separate  $\frac{T}{B} = \frac{S}{S}$   
 No Base  $\frac{T}{B} = \frac{S}{S}$

Rectangle  $\square$

Square  $\square$

Trapezoid  $\square$

Isosceles Trapezoid  $\square$

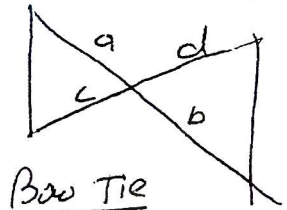

Bow Tie  
 $\frac{a}{b} = \frac{c}{d}$   
 2 (midsegment) = opposite side

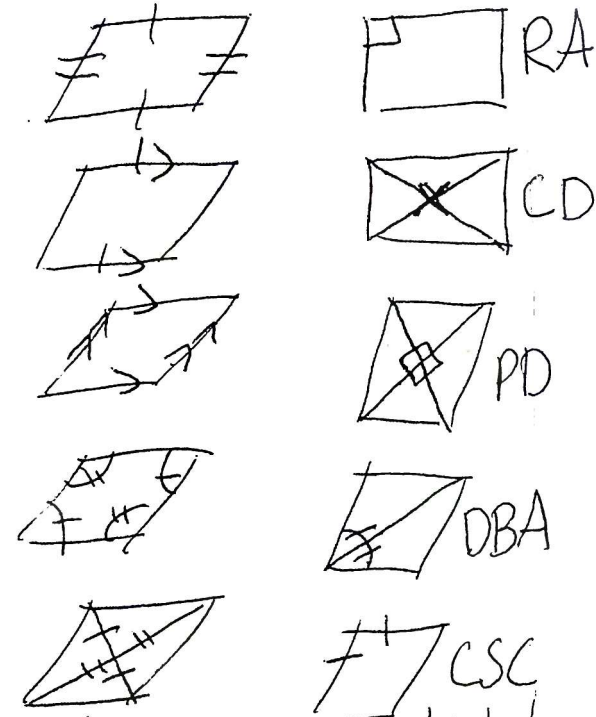

Rigid motion preserves size and angle measure, producing a congruent figure.  
 Identifying Transformations

CHECK ORIENTATION!

Same Not a single line reflection OR Rotation $\rightarrow$ state center Translation	different must be a single line reflection OR Reflection Translation
-----------------------------------------------------------------------------------------------------	-------------------------------------------------------------------------------------

Parallel lines have the same slope  
 Perpendicular lines have negative reciprocal slopes

$y - y_1 = m(x - x_1)$   
 \* might have to distribute and isolate y

Line Dilations  
 Parallel keep the slope!  
 Cheat!

Dilate Not origin: Dilate origin  
 Same line multiply scale factor and h

If the center of dilation is on the line, the image is the same line.

Prove Triangles  
 Prove 3 things  
 CPCTC for segments or angles

- 1) Min. Proofs
- 2) Additional tools (VRIAS)  
 Vertical angles are congruent  
 Reflexive Property  
 Isosceles Triangle theorem  
 Addition Property  
 Subtraction Property

\* IF you get stuck, make something up.

- 6 pointer
- 1) Prove P-gram
  - 2) Use P-gram for alternate interior angles  $\square$
  - 3) Prove triangles  $\cong$  or  $\sim$
- \* expect to have to do addition/subtraction property

Prove multiply, work backwards

$\triangle \sim \triangle$  AA  $\cong$  AA  
 $\frac{A}{D} = \frac{C}{B}$  CSSTIP

$A \cdot B = C \cdot D$  cross products are equal

The 2 smallest sides of a triangle add to be larger than the third side

Medians are cut in a ratio of 2:1

Cross sections  
 Perpendicular to base parallel to base  
 Prism/cylinder Pyramid/triangle  
 Rectangle triangle always base!

centroid  $\rightarrow$  medians  
 circumcenter  $\rightarrow$  perpendicular bisectors  
 incenter  $\rightarrow$  angle bisectors  
 orthocenter  $\rightarrow$  altitudes